

### HCJ-R

### Stem adapter BSPT

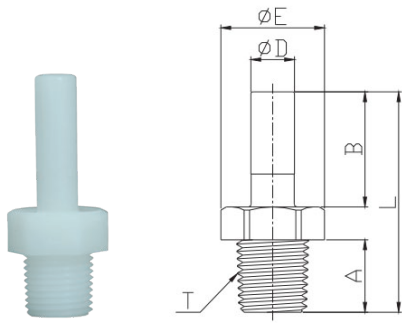

CODE	ØD	T	A	B	ØE	H	L	GR.
HCJ04R01W	4	R1/8"	9,1	18,0	14,4	13	33,1	1,8
HCJ04R02W	4	R1/4"	13,1	18,0	18,5	17	37,1	3,5
HCJ06R01W	6	R1/8"	9,1	19,5	14,4	13	34,6	2,0
HCJ06R02W	6	R1/4"	13,1	19,5	18,5	17	38,6	3,7
HCJ08R01W	8	R1/8"	9,1	21,0	14,4	13	36,1	2,2
HCJ08R02W	8	R1/4"	13,1	21,0	18,5	17	40,1	3,8
HCJ08R03W	8	R3/8"	13,5	21,0	23,0	21	40,5	5,3
HCJ10R02W	10	R1/4"	13,1	24,0	18,5	17	43,1	4,5
HCJ10R03W	10	R3/8"	13,5	24,0	23,0	21	44,0	6,1
HCJ10R04W	10	R1/2"	16,5	24,0	26,5	24	47,0	9,7
HCJ12R03W	12	R3/8"	13,5	28,0	23,0	21	48,0	6,8
HCJ12R04W	12	R1/2"	16,5	28,0	26,5	24	51,0	10,2

### HCJ-G

### Stem adapter BSPP

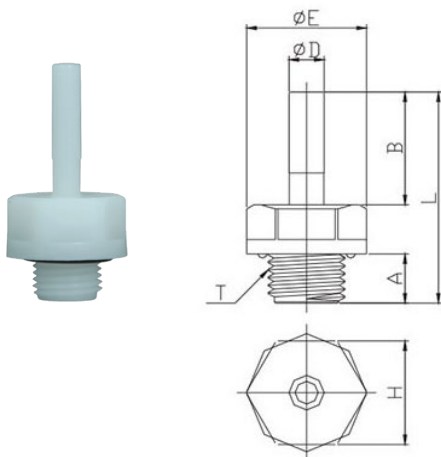

CODE	ØD	T	A	B	ØE	H	L	GR.
HCJ04G01W	4	G1/8"	6,0	18,0	16,6	15	32,5	2,7
HCJ04G02W	4	G1/4"	8,5	18,0	20,5	18	35,0	4,2
HCJ06G01W	6	G1/8"	6,0	19,5	16,6	15	34,0	2,8
HCJ06G02W	6	G1/4"	8,5	19,5	20,5	18	36,5	4,3
HCJ08G01W	8	G1/8"	6,0	21,0	16,6	15	35,5	3,0
HCJ08G02W	8	G1/4"	8,5	21,0	20,5	18	38,0	4,6
HCJ08G03W	8	G3/8"	9,0	21,0	24,2	22	38,5	6,2
HCJ10G02W	10	G1/4"	8,5	24,0	20,5	18	41,0	5,2
HCJ10G03W	10	G3/8"	9,0	24,0	24,2	22	41,5	6,8
HCJ10G04W	10	G1/2"	12,5	24,0	28,5	26	45,0	10,7
HCJ12G03W	12	G3/8"	9,0	28,0	24,2	22	45,5	7,3
HCJ12G04W	12	G1/2"	12,5	28,0	28,5	26	49,0	11,2
HCJ15G04W	15	G1/2"	12,5	36,0	28,8	26	57,0	13,8

### HUC

### Union connector

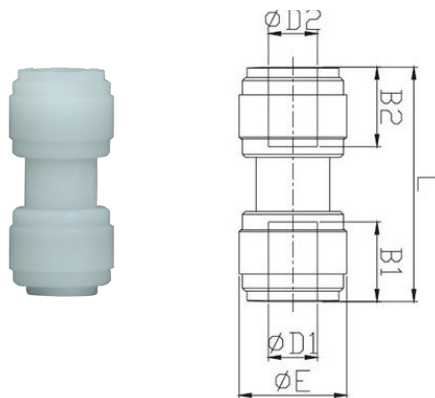

CODE	ØD1	ØD2	B1	B2	ØE	L	GR.
HUC0404W	4	4	14,7	14,7	13,2	31,8	3,8
HUC0606W	6	6	16,1	16,1	15,0	35,2	4,7
HUC0808W	8	8	17,5	17,5	17,6	38,2	6,9
HUC1010W	10	10	20,1	20,1	20,0	42,7	9,2
HUC1212W	12	12	24,7	24,7	23,0	52,4	14,4
HUC1515W	15	15	29,4	29,4	28,0	61,8	23,4
HUC2222W	22	22	33,8	33,8	35,5	70,6	37,7
HUC0604W	6	4	16,1	14,7	15,0	35,0	5,0
HUC0605W	6	5	16,1	14,9	15,0	35,1	5,0
HUC0806W	8	6	17,5	16,1	17,6	37,8	7,1
HUC1006W	10	6	20,1	16,1	20,0	42,0	9,8
HUC1008W	10	8	20,1	17,5	20,0	42,4	9,6
HUC1210W	12	10	24,7	20,1	23,0	51,7	15,0

